

# **(Preliminary) Outdoor Installation Guide**

**OH55DX, OH55DX-S  
OH46DX**

Follow the instructions provided in this guide when installing the product.  
Samsung will not provide warranty coverage for problems that may arise as a result of failure to follow the guide.  
The color and shape of the product may vary. In addition, instructions in the installation guide may change without prior notice when necessary to improve the product.

© Samsung Electronics  
Samsung Electronics owns the copyright for this manual.  
Use or reproduction of this manual in parts or entirety without the authorization of Samsung Electronics is prohibited.  
Trademarks other than Samsung Electronics are property of their respective owners.

---

## Notice

1. When installing signage, Samsung Electronics recommends that Signage is installed by itself, without an enclosure.
2. When installing signage with an enclosure, it requires the enclosure review process by engineering team in Samsung Electronics.
3. Samsung Electronics shall not be liable for any personal, or property loss resulting from direct installation of the product by the user.

# Prior to Installation

---

## Before Installing the Product

- To prevent injury, this apparatus must be securely attached to the floor/wall in accordance with the installation instructions from respective enclosure/mount company.
  - Ensure that the wall mount is installed by an authorized installation company. Otherwise, it may fall and cause personal injury.
  - Make sure to install the specified wall mount.
- If the product temperature is increased due to a high outdoor temperature or an installed environment, the luminance will decrease, and the overheating mitigation, and accident preventions will be hindered.

# Prior to Installation

## Installation Environment

- When installed in places such as a ski resort, fans may not operate if the inlet is blocked by a pile of snow. Install a cover to avoid snow piling directly onto the inlet.

- The product can be used in a train or subway station.
- The outdoor unit is designed to keep out iron dust.

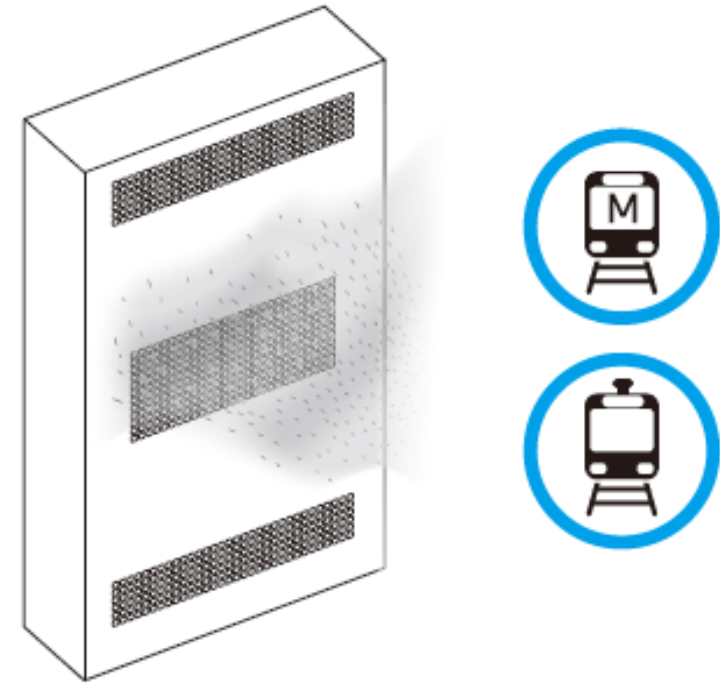
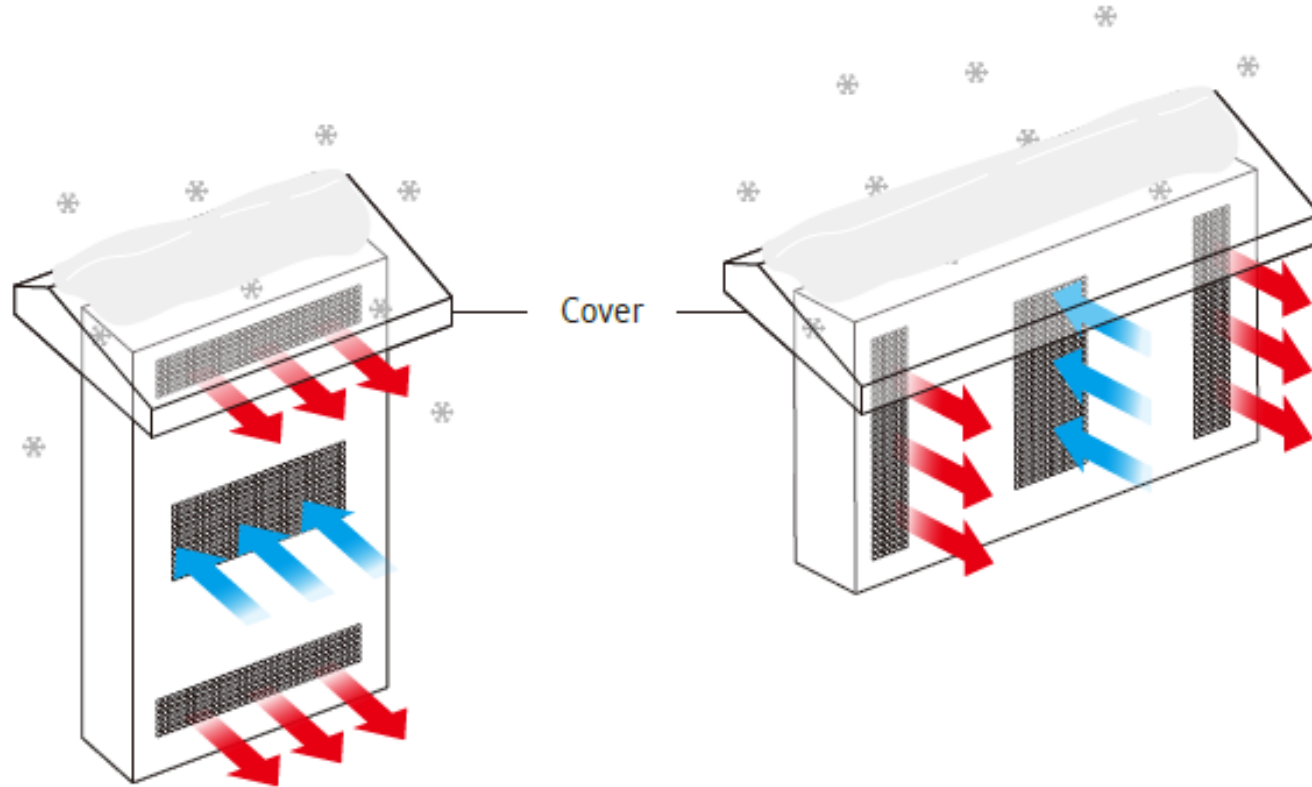

# Prior to Installation

---

## Installation Environment

- When installed on a beach front, make sure the display is placed where seawater is not accessible.
- ✎ Ensure the display unit installed location is within safe distance from the possible contact from rising seawater due to strong winds and storm or other natural phenomenon.



# Prior to Installation

## Rotation and Tilt Angle

- Display can be installed in Landscape or Portrait orientation. For portrait, only clockwise rotation is supported as shown below.
- Display can be installed in a tilted position on a vertical wall or an object, up to 15° in the forward direction.

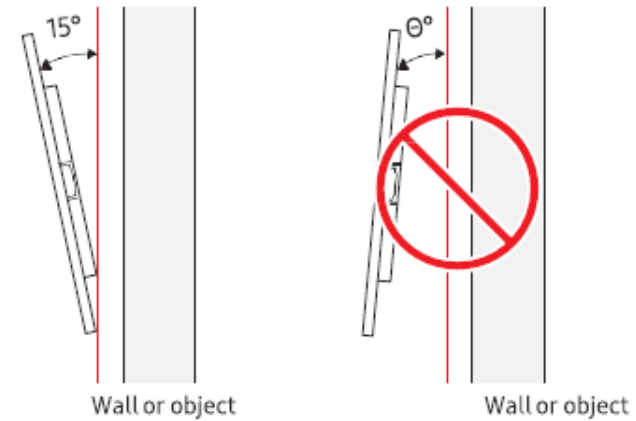
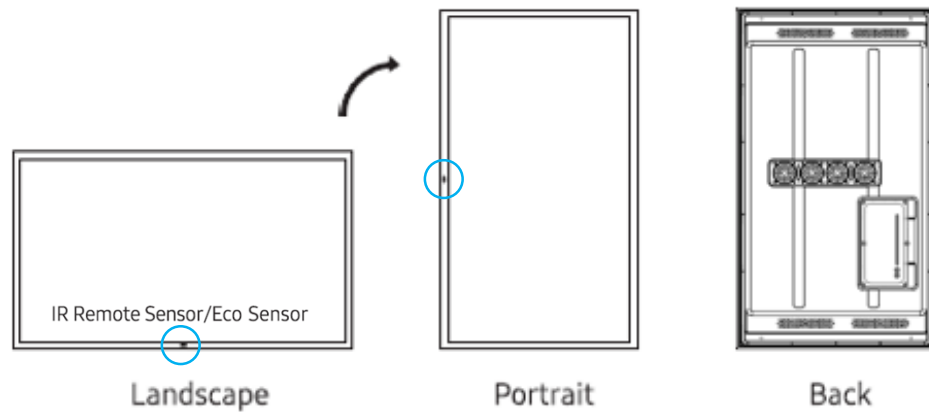

 Do not use this model installed on a ceiling, floor, or table.

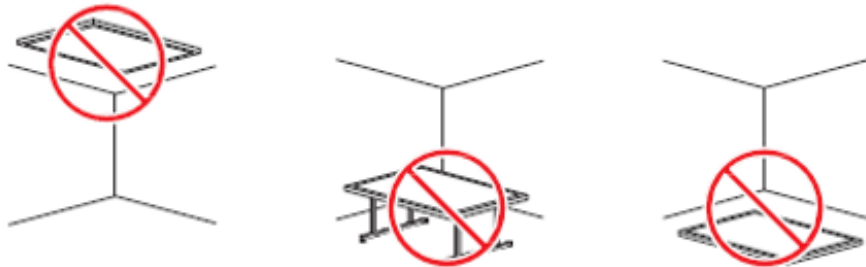

# Prior to Installation

## Air Flow Direction

- Display uses cooling fans to take in outside air to lower the internal temperature and discharge the hot air.  
✎ When installing an outdoor unit, remove any obstacles near the air inlet and outlet that may hinder air flow.

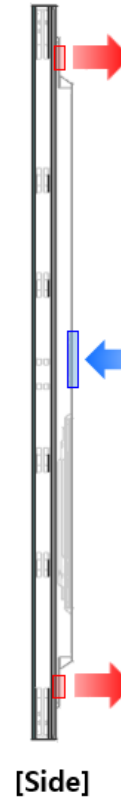
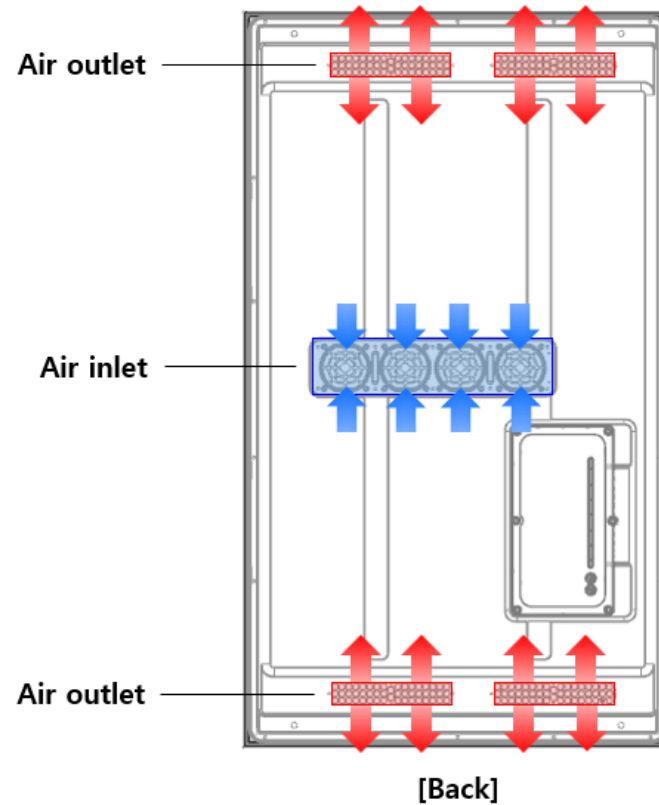
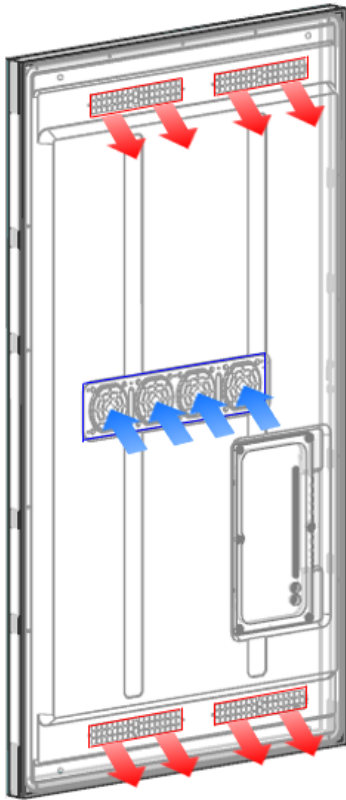

# Prior to Installation

## Mounting Hole Depth & Bolts

- M8 bolts are not included in the package. Use M8 bolts with appropriate Fastened bolt length per guidelines shown below.

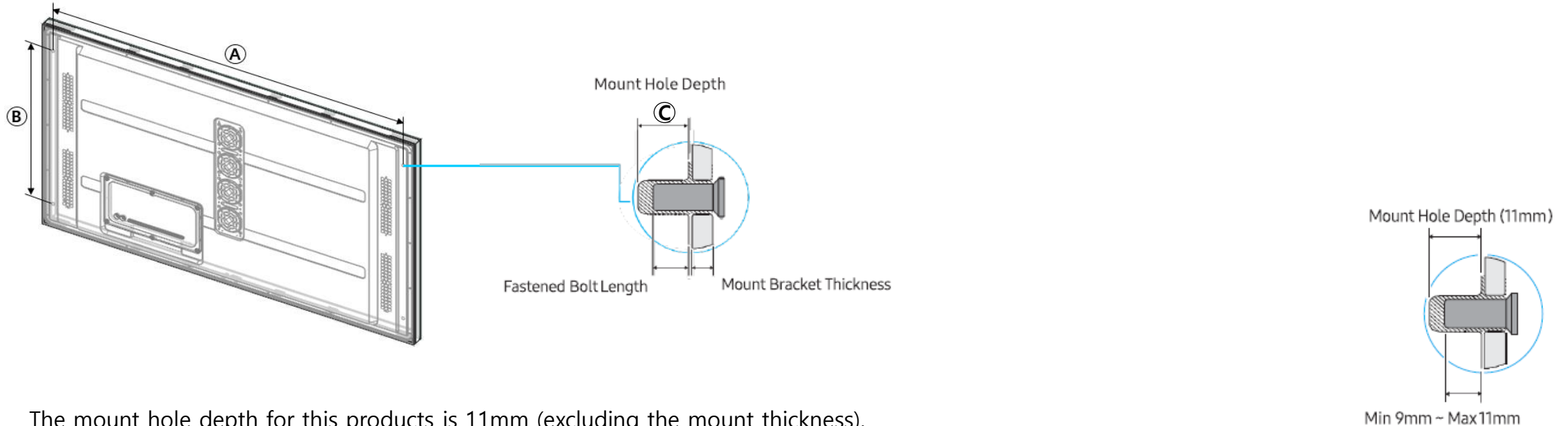

- The mount hole depth for this products is 11mm (excluding the mount thickness).
- Use the M8 bolts that can be fastened into at a minimum of 9mm depth to a maximum of 11mm depth after passing through the mount.  
(Torque : 12~15 kgf·cm)

 Samsung Electronics is not responsible for any damage to products or injuries caused by the use of bolts that do not meet our guidelines or are out of standard.

| Model name | Mount hole [ A x B ] (mm) | Mounted hole depth [ C ] (mm) | Standard screw | Fastened bolt length (mm) | Quantity |
|------------|---------------------------|-------------------------------|----------------|---------------------------|----------|
| OH45DX     | 995 x 500                 | 11                            | M8             | Min. 9 ~ Max. 11          | 4        |
| OH55DX(-S) | 1186 x 560                |                               |                |                           |          |

# Guide by Installation Type

## Wall-Mount Type Installation

- When installing close to the wall, maintain a sufficient clearance in order to secure air flow.
- Clearance (A) : 50mm or more
- Add partitions between the inlet and outlet to prevent discharged air from flowing back into the inlet.
- ✎ If the unit is subjected to excess heat due to an insufficient gap, this may cause a malfunction that will not be covered by the warranty.
- If the distance between the back of product and wall is too far to apply partition, the following types of partition can be installed.

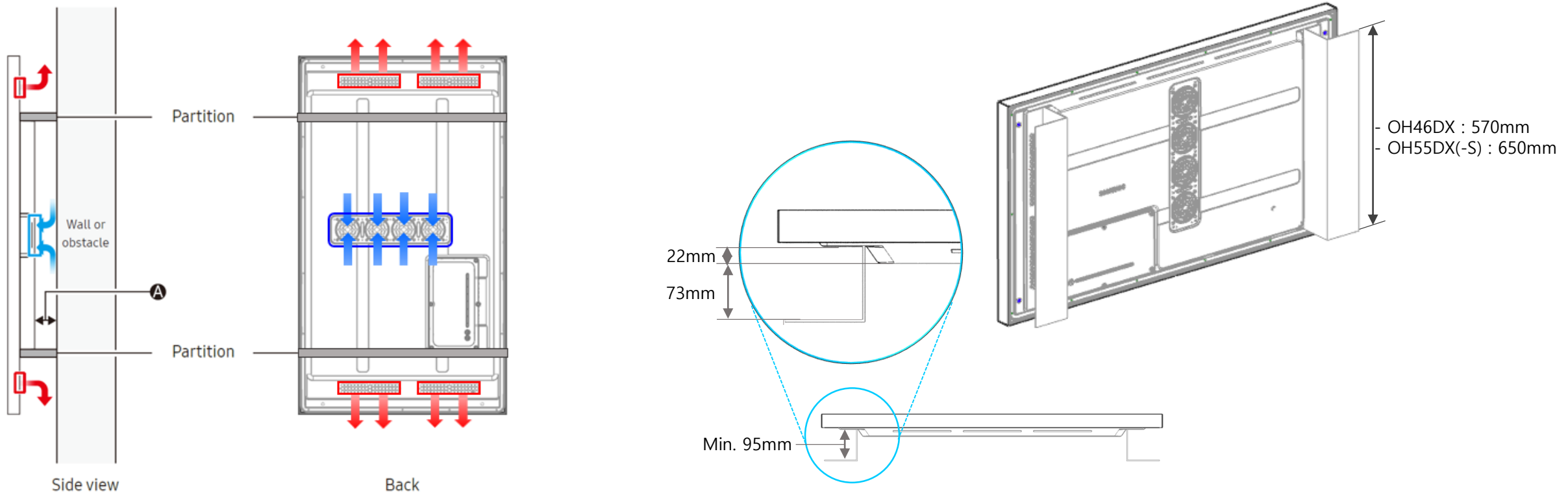

# Guide by Installation Type

## Indented Wall Mount Type Installation

- When installing on an indented wall, maintain the clearance from the back, top, bottom and sides of the product in order to ensure proper air-flow.
  - Clearance (A) : 50mm or more
  - Add partitions between the inlet and outlet to prevent discharged air from flowing back into the inlet.
-  If the unit is subjected to excess heat due to an insufficient gap, this may cause a malfunction that will not be covered by the warranty.

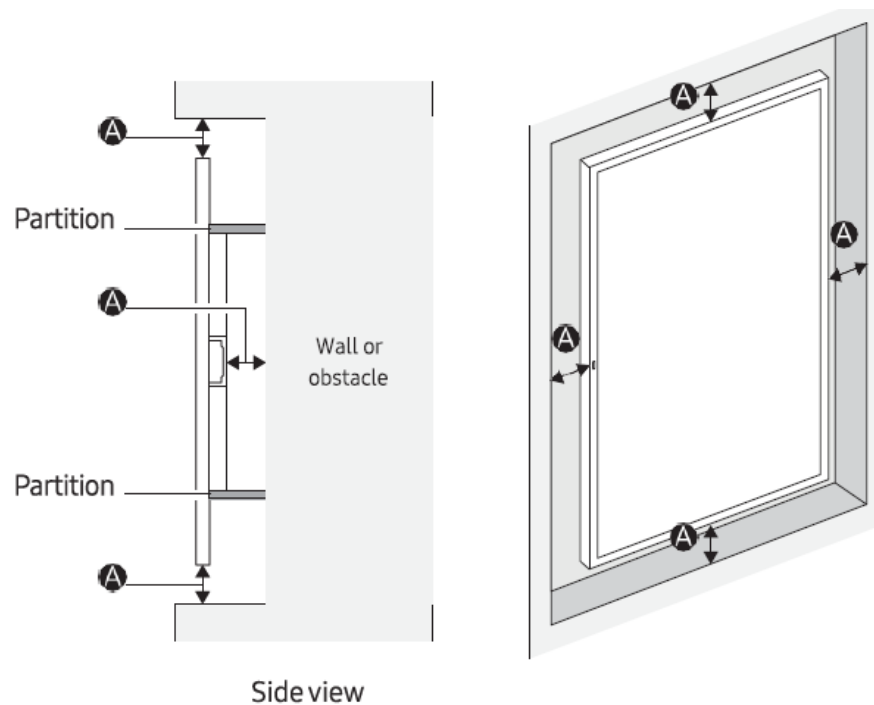

# Guide by Installation Type

## Clearance for Enclosure Installation

- When installing an enclosure unit close to the wall, maintain the clearance in order to secure air flow.
  - Consult your provider for detailed requirements before installing the display.
  - Excessive heat due to the use of the enclosure unit near an obstacle or a wall may cause a malfunction or a problem with the product.
  - Clearance (A) : 100mm or more
  - Remove any obstacles near the inlet and outlet that may hinder air flow.
-  If the unit is subjected to excess heat due to an insufficient gap, this may cause a malfunction that will not be covered by the warranty.

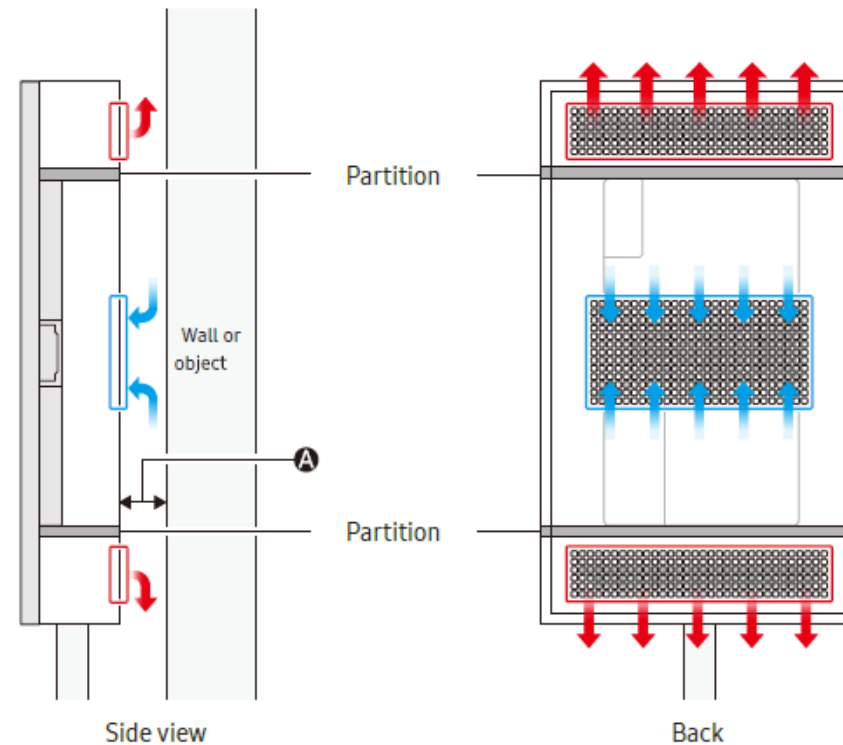

# Guide by Installation Type

## Design Guide for One-sided Single Enclosure

- Design the outdoor enclosure unit according to the following specification to prevent discharged hot air from flowing back to the inlet area.

### Total open area of the ventilation holes & opening ratio

- Air inlet : ②  
Total open area of the ventilation holes : 53,000mm<sup>2</sup> or more  
Ventilation opening ratio (% of total opening) : 50% or more
- Air outlet : ①, ③  
Total open area of the ventilation holes (①) : 29,000mm<sup>2</sup> or more  
Total open area of the ventilation holes (③) : 29,000mm<sup>2</sup> or more  
Ventilation opening ratio (% of total opening) : 50% or more

✎ Design the locations of the outdoor enclosure unit's inlet and outlet areas to match the respective locations of display's inlet and outlet areas.

### Clearance between inlet and outlet areas

| Model name | Minimum separation distance (E) (mm) |
|------------|--------------------------------------|
| OH46DX     | 235                                  |
| OH55DX(-S) | 286                                  |

✎ Ensure minimum clearance between inlet and outlet areas of the enclosure.

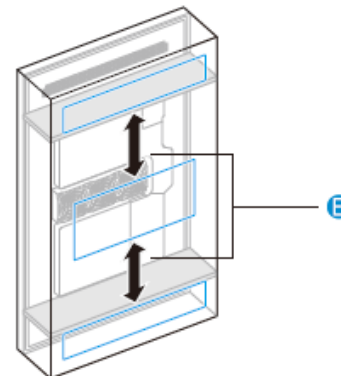

Example 1

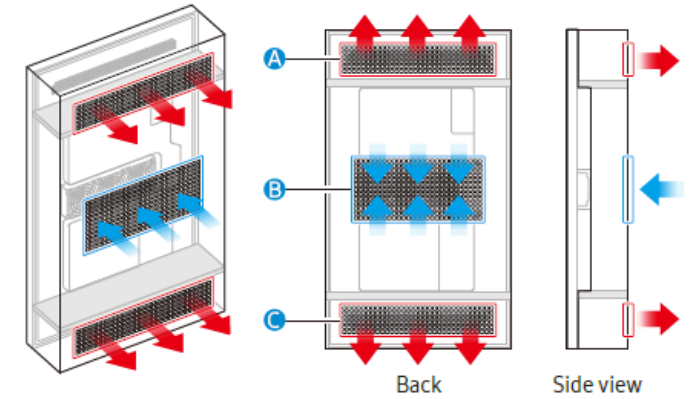

Example 2

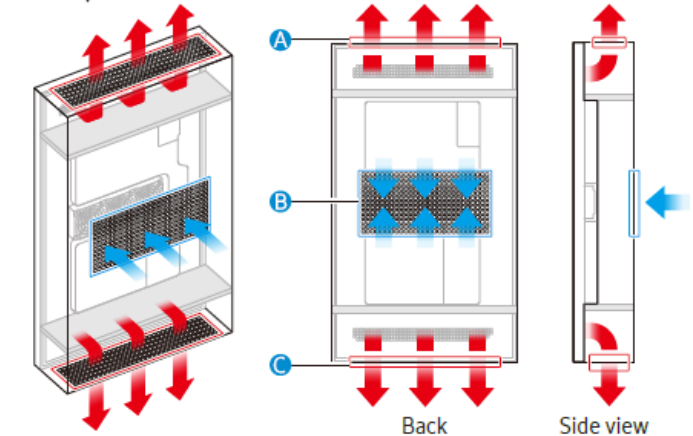

# Guide by Installation Type

## Design Guide for Double-Sided Single Enclosure

- Design the outdoor enclosure unit to keep discharged hot air from flowing back into the inlet.
- ✎ When designing double-sided enclosure units, the outlet can be positioned on the top, bottom, or sides.

### Total open area of the ventilation holes & opening ratio

- Air inlet : ㊀
  - Total open area of the ventilation holes : 106,000mm<sup>2</sup> or more
  - Ventilation opening ratio (% of total opening) : 50% or more
- Air outlet : ㊁, ㊂
  - Total open area of the ventilation holes (㊁) : 58,000mm<sup>2</sup> or more
  - Total open area of the ventilation holes (㊂) : 58,000mm<sup>2</sup> or more
  - Ventilation opening ratio (% of total opening) : 50% or more
- Clearance between outdoor displays (㊃) : 100mm or more

### Clearance between inlet and outlet areas

| Model name | Minimum separation distance (㊃) (mm) |
|------------|--------------------------------------|
| OH46DX     | 235                                  |
| OH55DX(-S) | 286                                  |

- ✎ Ensure minimum clearance between inlet and outlet areas of the enclosure.

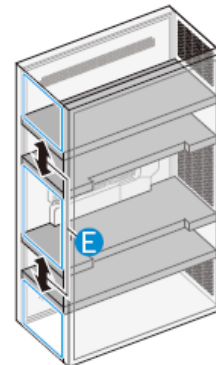
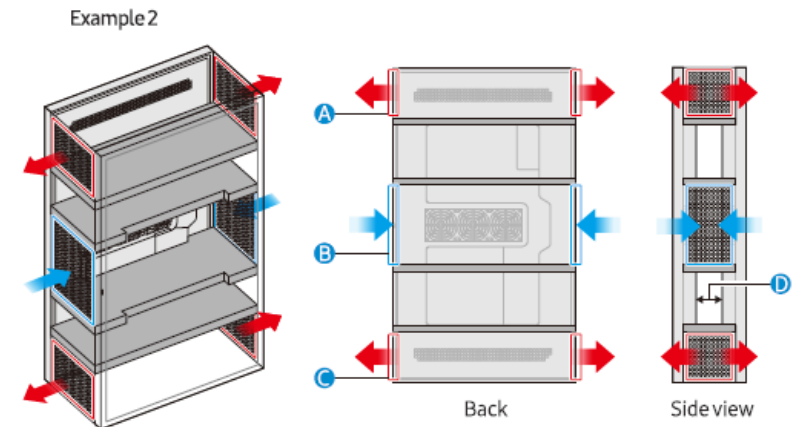
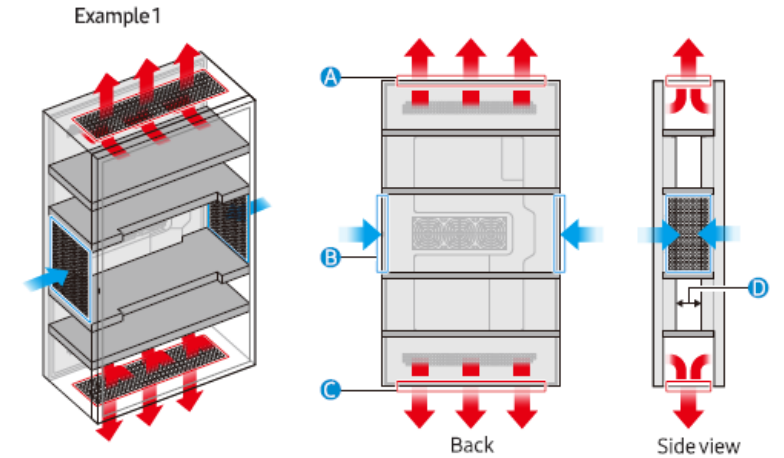

# Guide by Installation Type

## Design Guide for Ventilation hole on Enclosure

### Type of Ventilation Hole on Enclosure

- Air inlet and outlet of Enclosure should be grid or mesh types.
- ✎ Do not use the louver type as it has a limited intake area.

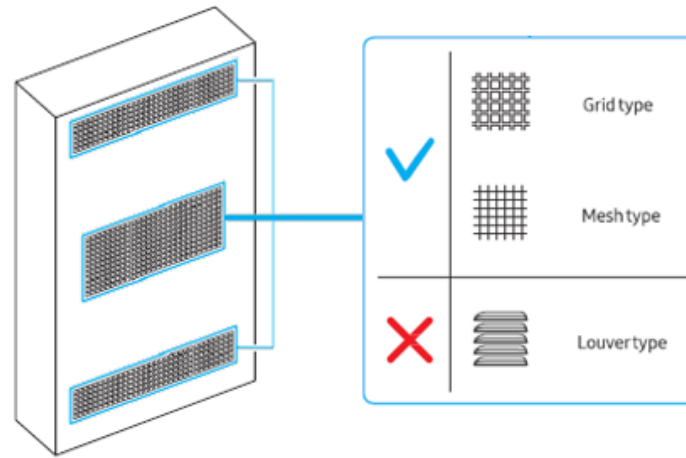

### Total Open Area of the Ventilation Holes and Opening Ratio

- Follow the guide when placing the outdoor display within the enclosure unit.
- ✎ If the instructions provided in this guide are not observed, the cooling system may not work properly and may cause a malfunction, which will not be covered by warranty.
- ✎ Example of calculating total open area and opening ratio of ventilation as shown below.

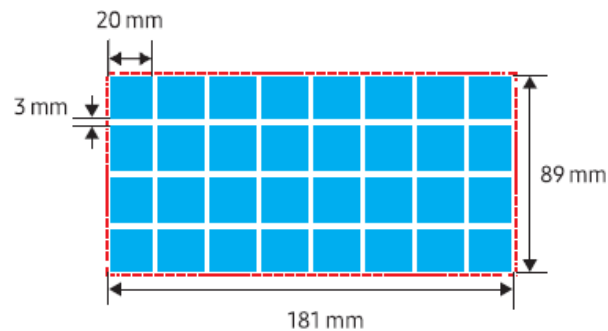

 Total Area of the Ventilation:  $181 \times 89 = 16109 \text{ mm}^2$

 Total open area of Ventilation holes :  $20 \times 20 \times 32 = 12800 \text{ mm}^2$

$$\text{Ventilation opening ratio} = \frac{\text{Total open area of Ventilation holes}}{\text{Total Area of the Ventilation}}$$
$$= \frac{12800 \text{ mm}^2}{16109 \text{ mm}^2} \times 100 = 79 \%$$

# Guide by Installation Type

## Design Guide for Partitions in Enclosure

### Partitions for Inlet and Outlet

- For outdoor units, add partitions between the inlet and outlet areas inside the enclosure unit to maintain separate air paths.
- Partitions should fit perfectly inside the enclosure unit, with no gap between the outdoor display and enclosure unit.
- If there is a gap, use a foam tape to fill in the gap.

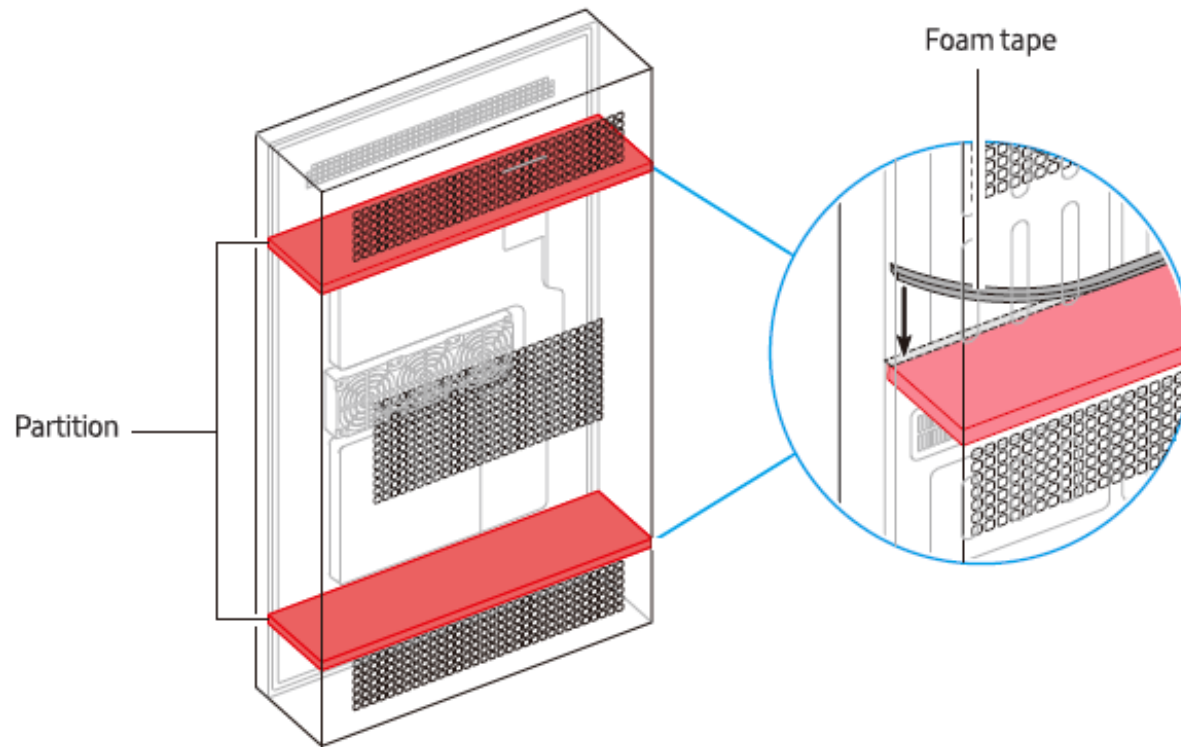

# Guide by Installation Type

---

## Design Guide for Partitions in Enclosure

### Partition for optional media player or external devices

- To install an optional media player or external devices with the outdoor display, use partitions to isolate devices.
  - ✎ There should be no gap between the media player and outdoor display; only allow cables through the partition.
  - ✎ The optional media player or external devices are additional source of heat and the increased temperature inside the enclosure unit may cause the outdoor display to malfunction; a malfunction occurring in this manner will not be covered by the warranty.

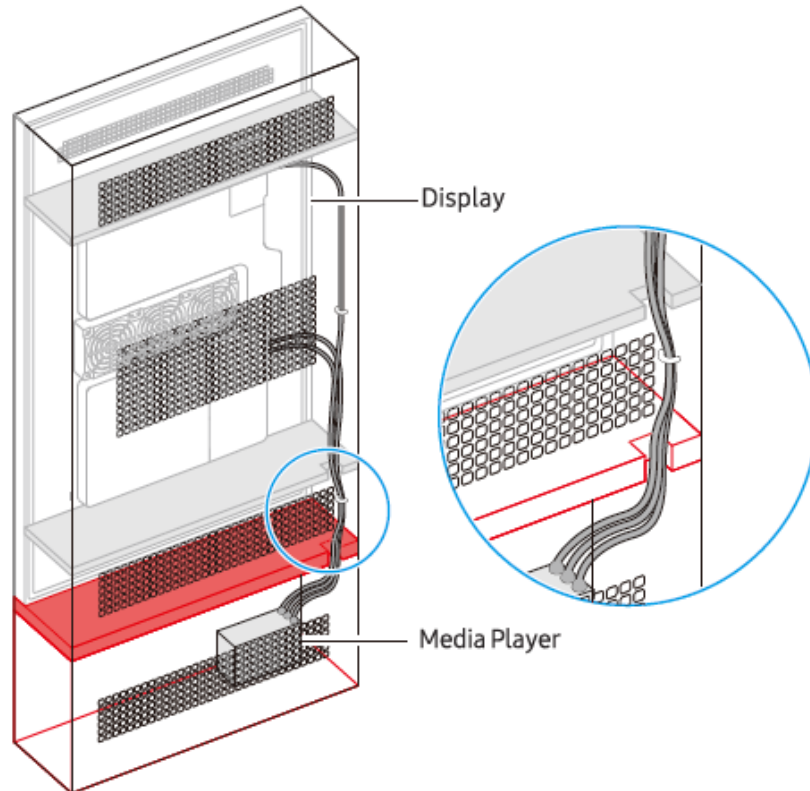

# Guide by Installation Type

---

## Design Guide for 1 x N One-Sided Enclosure

- When designing the 1 x N one-sided enclosure unit, add partitions between the products to separate the air paths.
  - ✎ Refer to the 'Total open area of the ventilation holes and ratio'. ([Page 11](#))
  - ✎ Make sure there is no gap between the partitions and the enclosure unit.

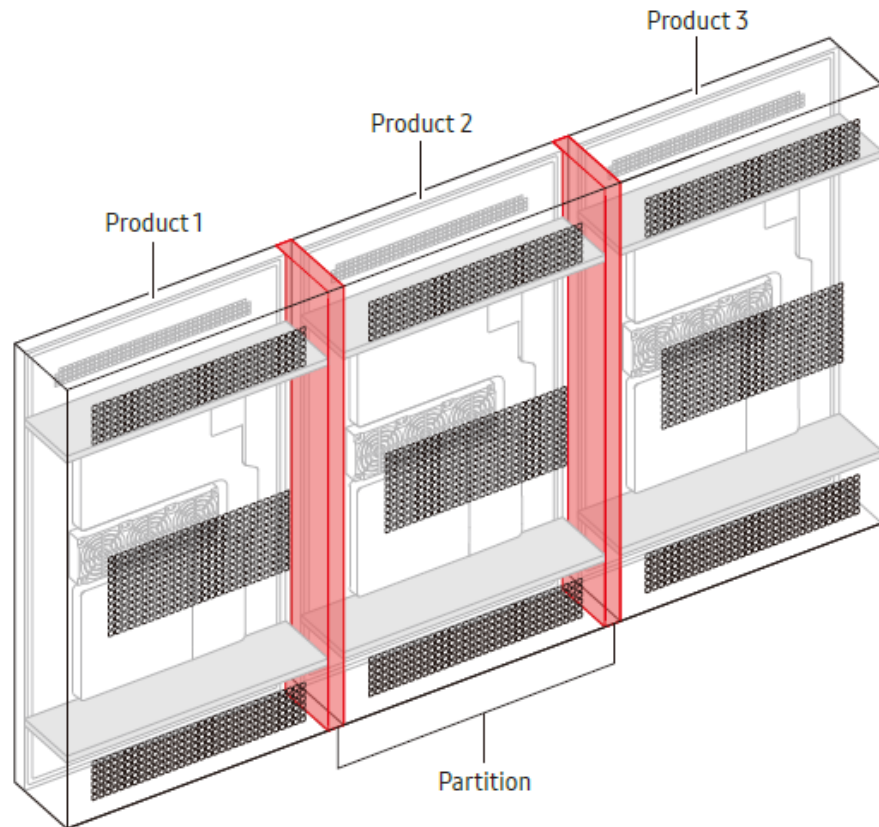

# Guide by Installation Type

---

## Design Guide for Secondary Glass on Enclosure

### Important note

- The primary glass on OHDX(-S) is a tempered Magic Protection Glass, with the durability of IK10 rating. IK10 rating ensures the advanced safety and protection against the external impact and damage. The 2<sup>nd</sup> glass is optional for customers looking for additional protection on OHDX(-S) displays.
- The 2<sup>nd</sup> glass must be installed per Thermal Guide requirements. The procurement, installation, maintenance, and replacement are the responsibility of 3<sup>rd</sup> party labor, SI, or enclosure OEM. The size and thickness of the glass will be determined by the 3<sup>rd</sup> party.
- Please note that the recommended material is glass. The poly carbonate material types should be avoided since the exposure may cause unwanted deflections (reducing the air gap of 10mm), and discoloration over time.
- Samsung will not be responsible for the reduced readability and picture quality caused by the installation of secondary glass due to the reflections, and transmittance and color characteristics of glass itself.

# Guide by Installation Type

## [46"] Design Guide for Secondary Glass on Enclosure

### Minimum gap and total open area

- The minimum gap (A) and open area (C+D+E) between secondary glass and display must meet the following conditions.
- The placement of open areas on each Open ID should be distributed throughout evenly in order to allow even flow of inlet, and outlet air. The hot outlet air should not be stagnant between display and secondary glass.

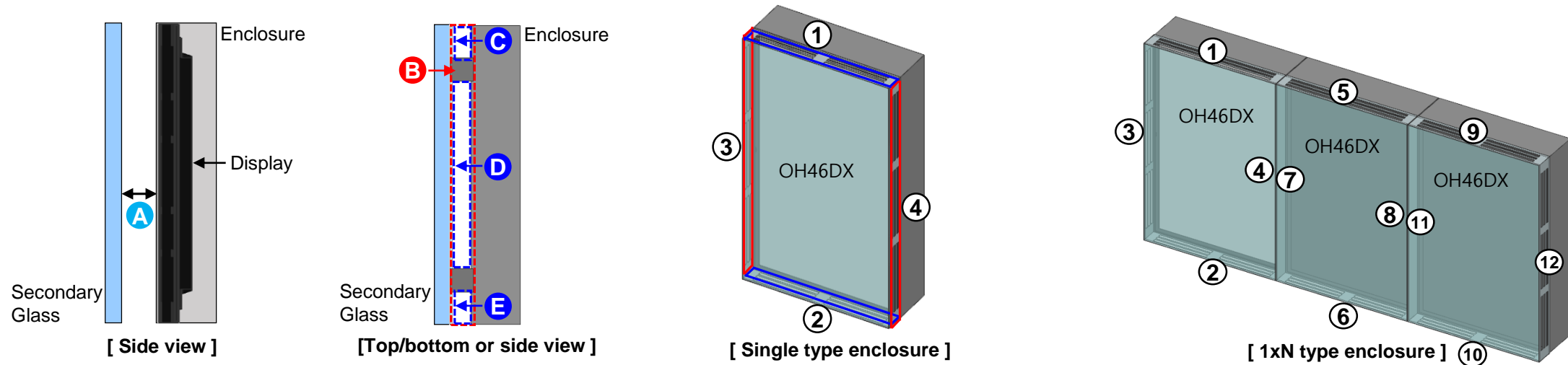

| Enclosure type (1xN)      | Minimum gap (A) | Open(vent) location            | Open ID          | Minimum total open area | Opening ratio                            |
|---------------------------|-----------------|--------------------------------|------------------|-------------------------|--|
| OH46DX<br>N=1<br>(single) | 10mm            | All<br>(Top/Bottom/Left/Right) | ①, ②             | 5,300 mm <sup>2</sup>   | $\frac{(C+D+E)}{B} \times 100 \geq 50\%$ |
|                           |                 |                                | ③, ④             | 8,552 mm <sup>2</sup>   |  |
|                           |                 | Top/Bottom                     | ①, ②             | 6,236 mm <sup>2</sup>   |  |
|                           |                 | Bottom/Left/Right              | ②                | 6,236 mm <sup>2</sup>   |  |
|                           |                 |                                | ③, ④             | 9,086 mm <sup>2</sup>   |  |
| N=2 (side by side)        |                 | Top/Bottom                     | ①, ②, ⑤, ⑥       | 6,236 mm <sup>2</sup>   |  |
| N=3 (side by side)        |                 | Top/Bottom                     | ①, ②, ⑤, ⑥, ⑨, ⑩ | 6,236 mm <sup>2</sup>   |  |

# Guide by Installation Type

## [Example] Minimum gap and total open area

- The gap between secondary glass and display : 20mm

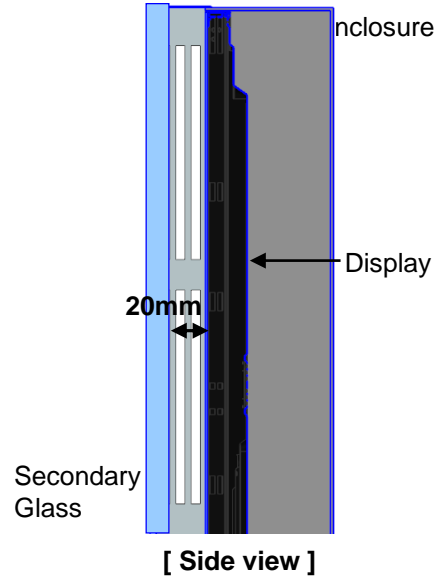

- Enclosure type : Single type, only Top closed

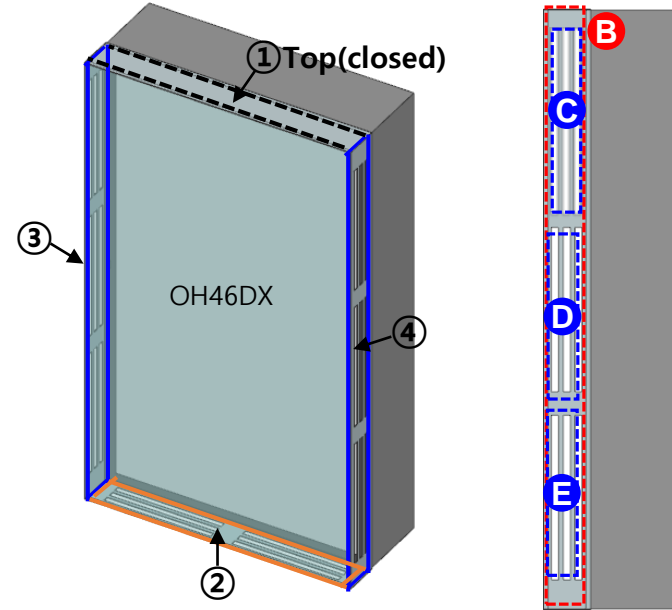

[Example] Opening ratio  
 Total area(B) : 21,380 mm<sup>2</sup>  
 Open area(C+D+E) : 10,500 mm<sup>2</sup>  
 Opening ratio : 49.1%  

$$\frac{10,500 \text{ mm}^2}{21,380 \text{ mm}^2} \times 100 = 49.1\%$$

| Enclosure type (1xN)      | Glass gap            | Open(vent) location |   | Guide                  | Open area              | Opening ratio | Result |
|---------------------------|----------------------|---------------------|---|------------------------|------------------------|---------------|--------|
| OH46DX<br>N=1<br>(single) | 20mm<br>(OK, 10mm ↑) | Bottom              | ② | ≥6,236 mm <sup>2</sup> | 6,000 mm <sup>2</sup>  | 48.1%         | NG     |
|                           |                      | Left                | ③ | ≥9,086 mm <sup>2</sup> | 13,000 mm <sup>2</sup> | 60.8%         | OK     |
|                           |                      | Right               | ④ | ≥9,086 mm <sup>2</sup> | 10,500 mm <sup>2</sup> | 49.1%         | NG     |

# Guide by Installation Type

## [55"] Design Guide for Secondary Glass on Enclosure

### Minimum gap and total open area

- The minimum gap (A) and open area (C D E) between secondary glass and display must meet the following conditions.
- The placement of open areas on each Open ID should be distributed throughout evenly in order to allow even flow of inlet, and outlet air. The hot outlet air should not be stagnant between display and secondary glass.

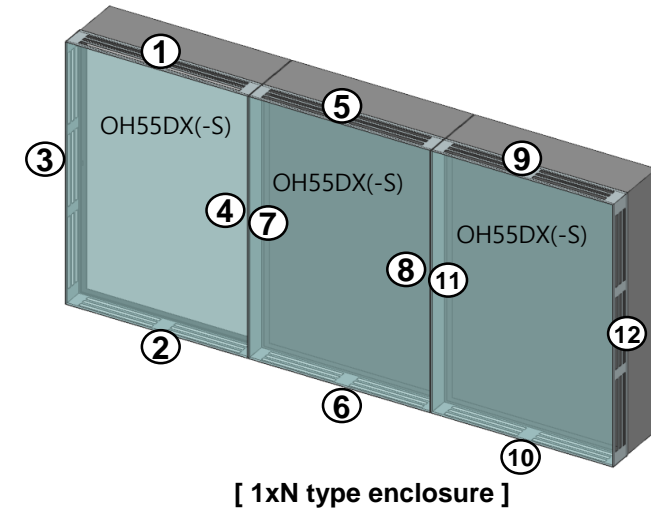
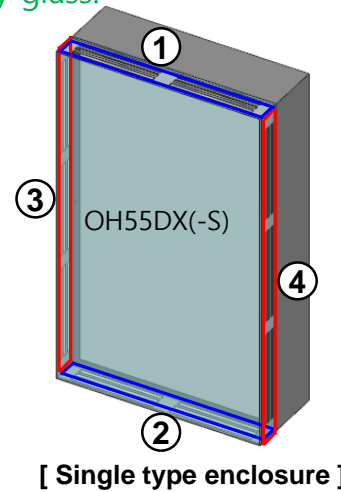
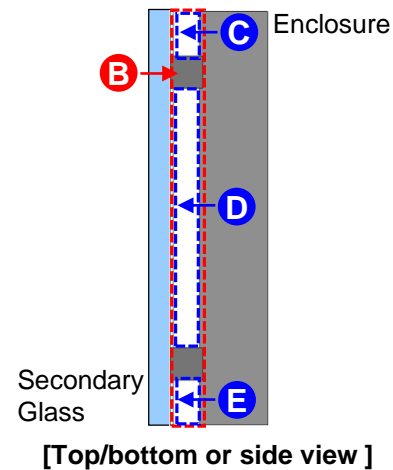
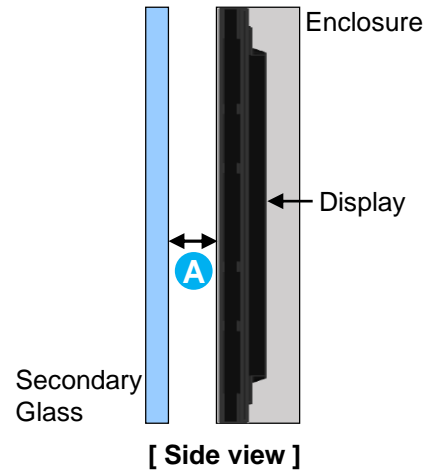

| Enclosure type (1xN)          | Minimum gap (A) | Open(vent) location            | Open ID          | Minimum total open area | Opening ratio                            |
|-------------------------------|-----------------|--------------------------------|------------------|-------------------------|--|
| OH55DX(-S)<br>N=1<br>(single) | 10mm            | All<br>(Top/Bottom/Left/Right) | ①, ②             | 6,217 mm <sup>2</sup>   | $\frac{(C+D+E)}{B} \times 100 \geq 50\%$ |
|                               |                 |                                | ③, ④             | 10,085 mm <sup>2</sup>  |  |
|                               |                 | Top/Bottom                     | ①, ②             | 7,314 mm <sup>2</sup>   |  |
|                               |                 | Bottom/Left/Right              | ②                | 7,314 mm <sup>2</sup>   |  |
|                               |                 |                                | ③, ④             | 10,715 mm <sup>2</sup>  |  |
| N=2 (side by side)            |                 | Top/Bottom                     | ①, ②, ⑤, ⑥       | 7,314 mm <sup>2</sup>   |  |
| N=3 (side by side)            |                 | Top/Bottom                     | ①, ②, ⑤, ⑥, ⑨, ⑩ | 7,314 mm <sup>2</sup>   |  |

# Guide by Installation Type

## [Example] Minimum gap and total open area

- The gap between secondary glass and display : 20mm

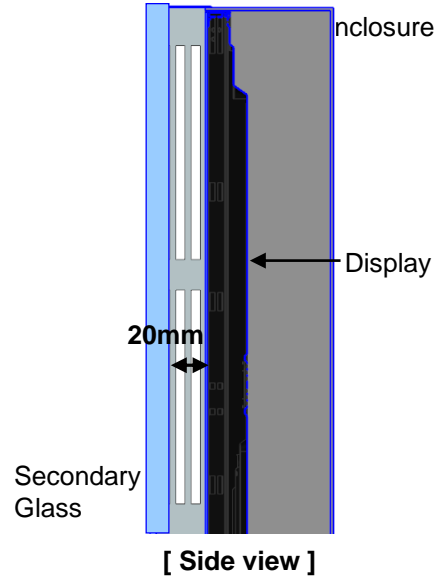

- Enclosure type : Single type, only Top closed

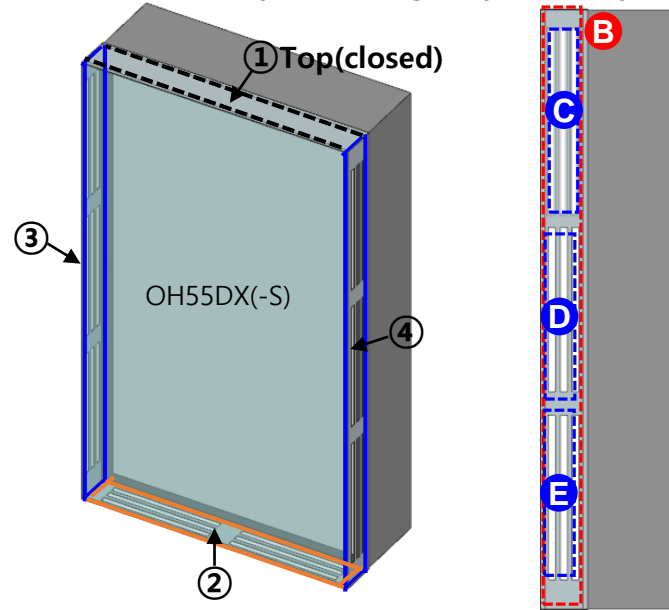

[Example] Opening ratio

Total area(B) : 25,212 mm<sup>2</sup>

Open area(C+D+E) : 12,000 mm<sup>2</sup>

Opening ratio : 47.6%

$$\frac{12,000 \text{ mm}^2}{25,212 \text{ mm}^2} \times 100 = 47.6\%$$

| Enclosure type (1xN)          | Glass gap            | Open(vent) location |   | Guide                   | Open area              | Opening ratio | Result |
|-------------------------------|----------------------|---------------------|---|-------------------------|------------------------|---------------|--------|
| OH55DX(-S)<br>N=1<br>(single) | 20mm<br>(OK, 10mm ↑) | Bottom              | ② | ≥7,314 mm <sup>2</sup>  | 7,200 mm <sup>2</sup>  | 49.2%         | NG     |
|                               |                      | Left                | ③ | ≥10,715 mm <sup>2</sup> | 15,000 mm <sup>2</sup> | 59.5%         | OK     |
|                               |                      | Right               | ④ | ≥10,715 mm <sup>2</sup> | 12,000 mm <sup>2</sup> | 47.6%         | NG     |

# Guide by Installation Type

## Wi-Fi/BT Module Installation

### Wi-Fi/BT Module Cable Connection

- The connection type is USB. Wi-Fi/BT Module cable must be connected to **USB2.0 (External Wi-Fi/BT)** port of the OHDX(-S).
  - Rebooting display is required after connecting the external Wi-Fi/BT module cable.
  - Wi-Fi/BT module is compatible with OHDX(-S) product only and vice versa.
  - Length of cable is 1.5m. It is not allowed to use 3<sup>rd</sup> party USB extension cable or USB hub in order to extend cable length.
- ✎ Please consider the length of cable prior to designing enclosure.
- ✎ Wi-Fi/BT module accessory is sold separately.(OHDX)

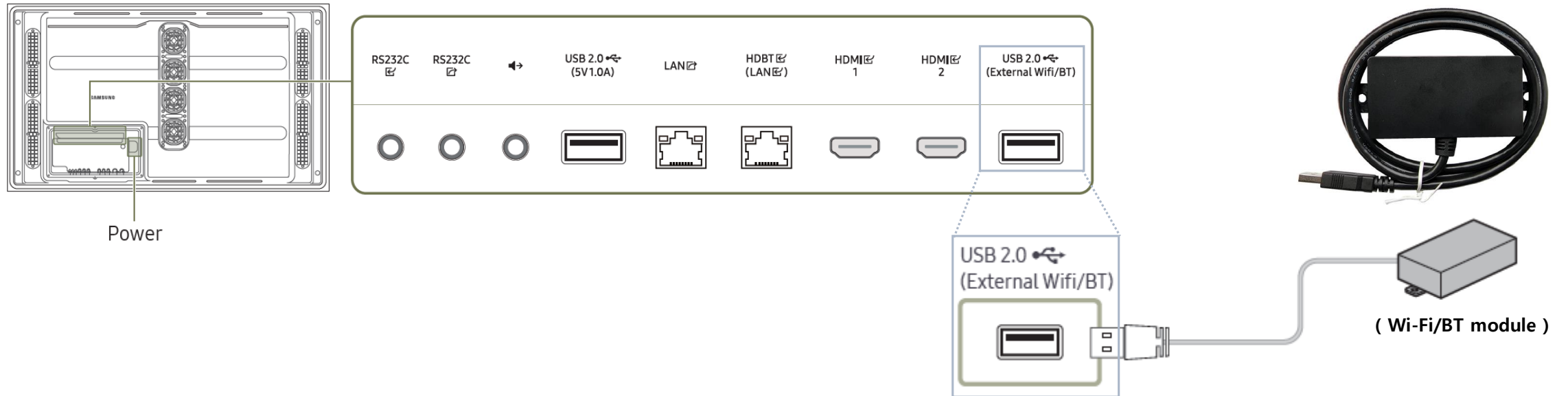

# Guide by Installation Type

## Wi-Fi/BT module & cable dimension

- Wi-Fi/BT module can be mounted on enclosure using the form tape enclosed with the module.
- 2 bolt holes for mounting are already on Wi-Fi/BT module. Bolts are not included in the package.

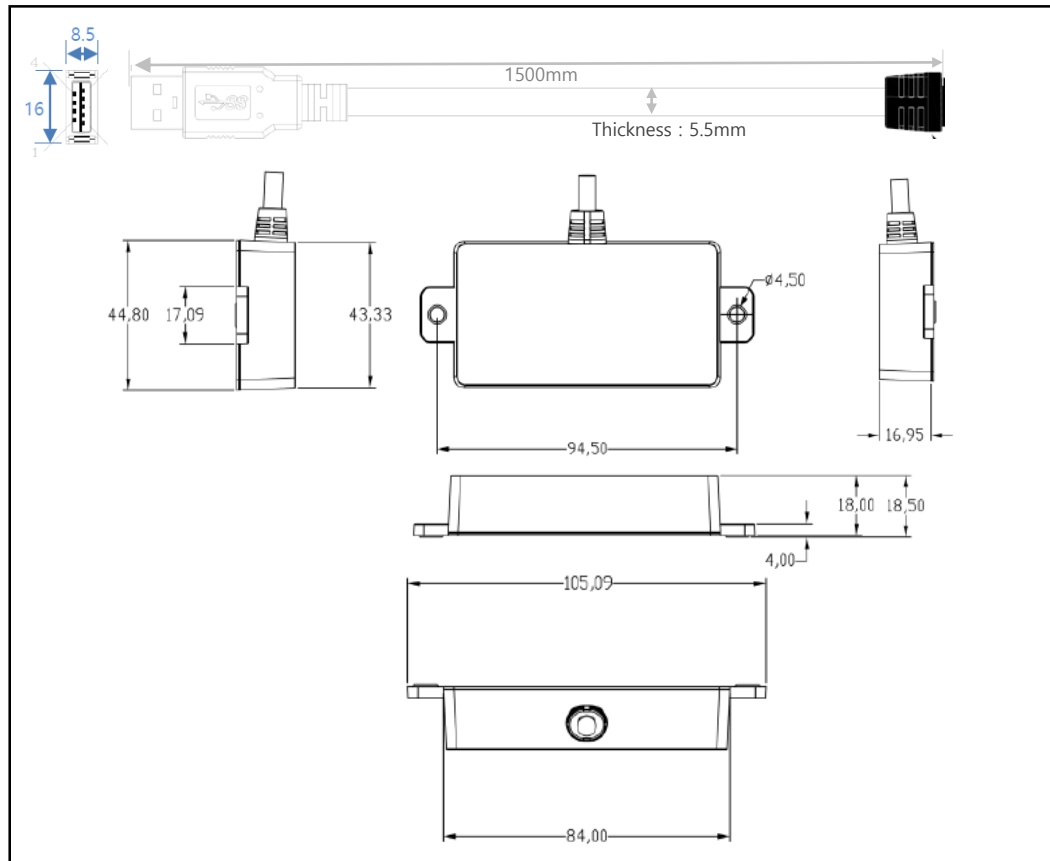

Dimension of module case and cable

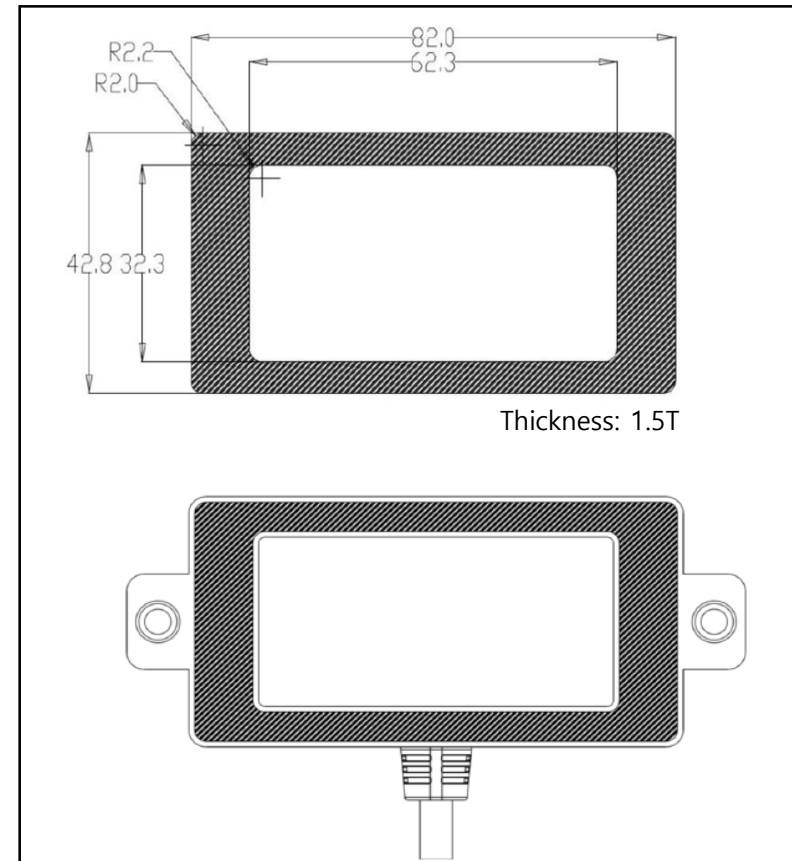

Form tape on bottom case

# Guide by Installation Type

## Wi-Fi/BT module installation

- Consider the location & direction of Wi-Fi module when designing enclosure.
- Wi-Fi module can receive Wi-Fi signal through all areas of module except the bottom area as shown on Picture (a) below. The optimized area for the best input signal is shown on Picture (b) below.
- Please make sure that Wi-Fi signal receivable area of module mentioned above should be exposed to outside of enclosure and towards Wi-Fi AP.
- Wi-Fi signal receivable area of module must face Wi-Fi AP. Any metallic obstacles including OHDX(-S) itself should not be located between Wi-Fi module and Wi-Fi AP.
- It is recommended that the module be positioned within 10m of Wi-Fi AP.

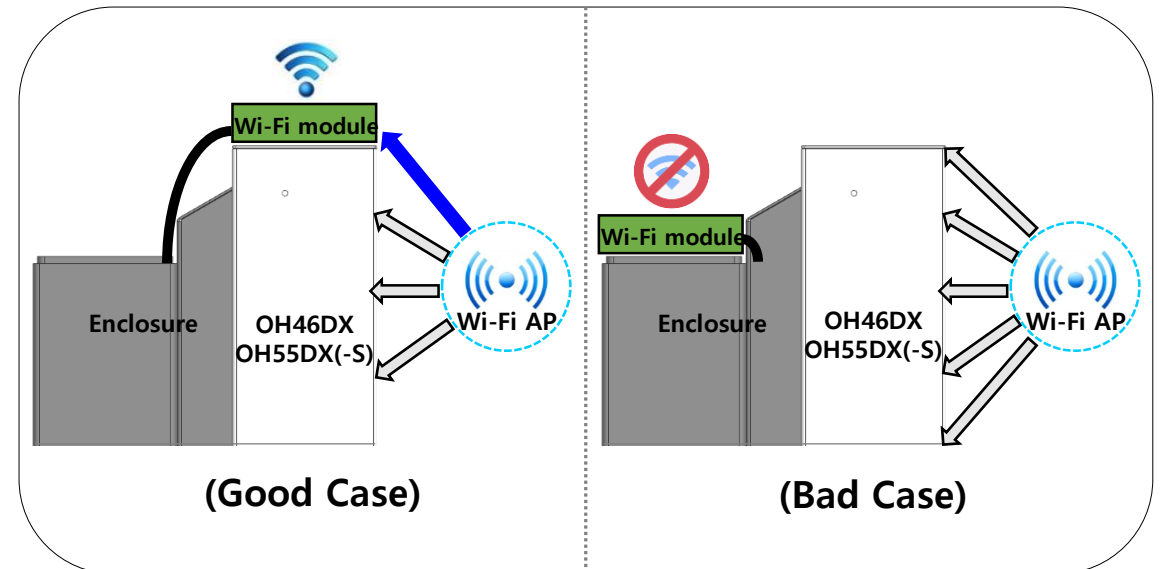
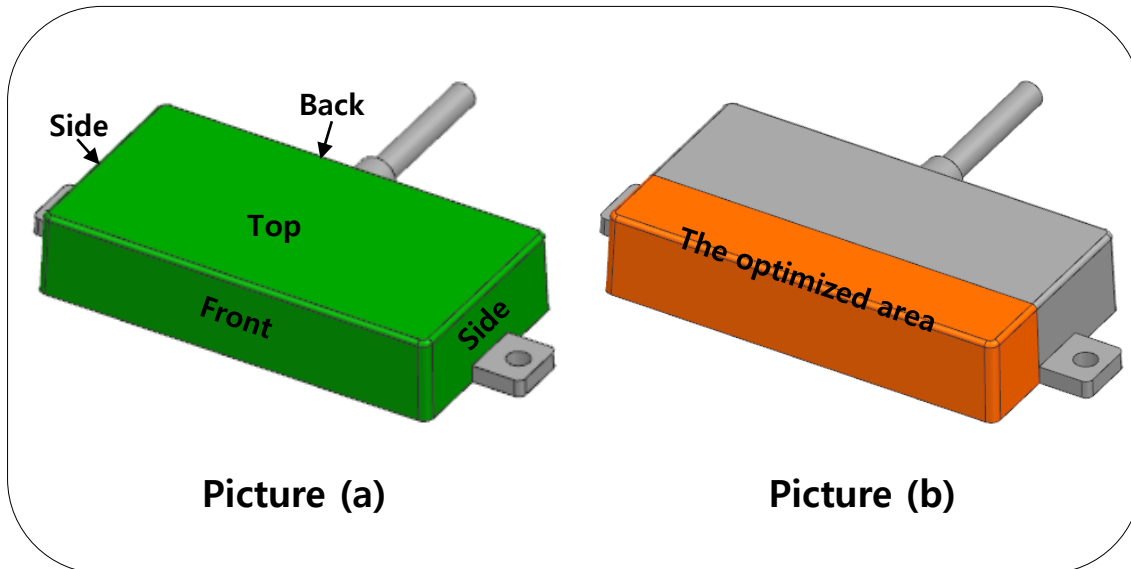

# Guide by Installation Type

---

## IR Remote and Eco Sensor

### IR remote and Eco sensor

- Consider the location of IR remote and Eco sensor on the display when designing an enclosure unit.
  - ✎ The sensor may cause the screen to darken if the sensor is not sufficiently exposed to ambient light source.

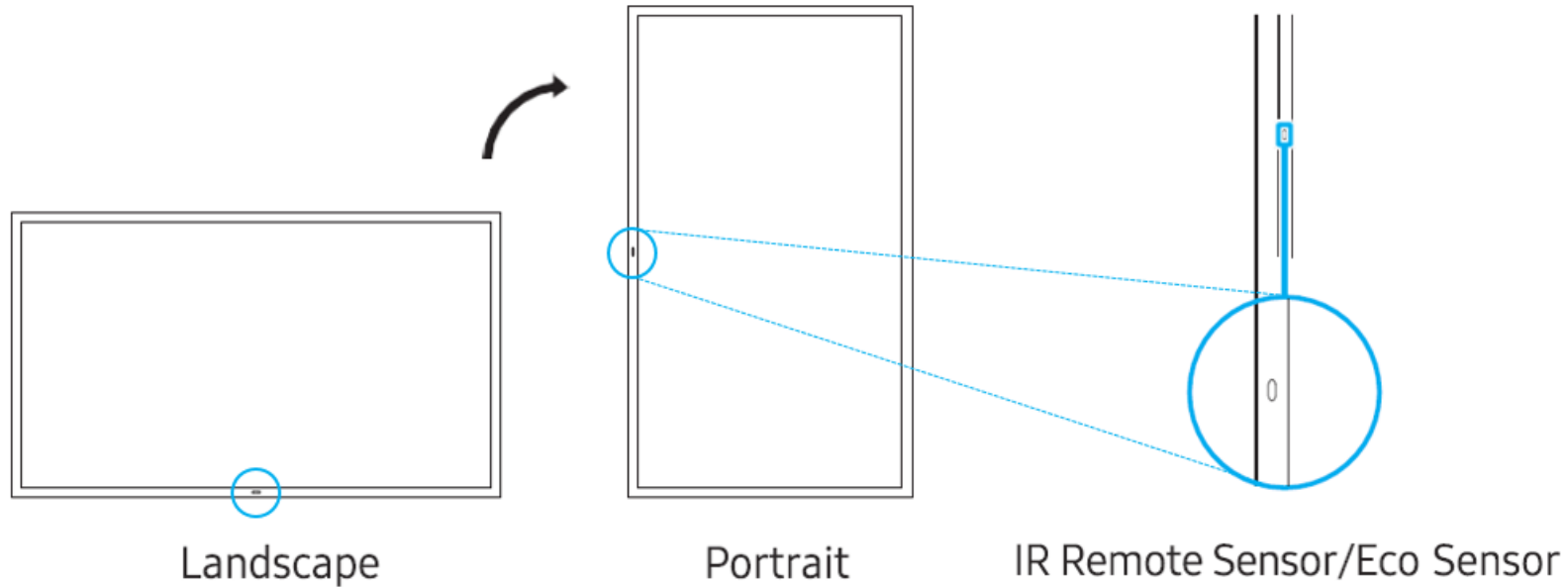

# Cautions

## Cautions when routing cables

- Route cables connected to the outdoor unit in a manner that keeps them away from water.
-  Use the provided Samsung power cable only.

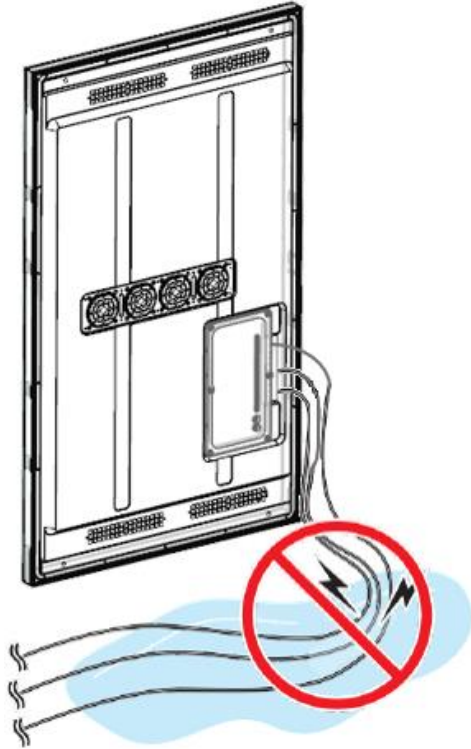

- When installing the 1 x N one sided enclosure unit, route cable away from the inlet and outlet area.

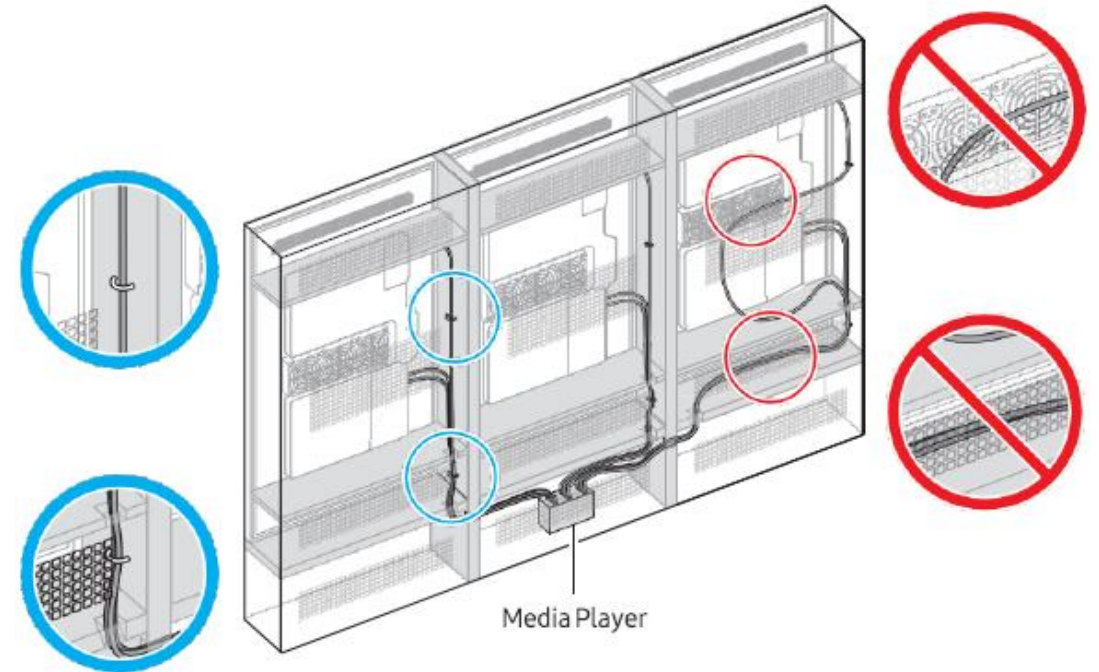

# Cautions

## Cautions when connecting cables

- Remove the appropriate silicon bar before connecting cables.
  - $\Phi 8$  hole x 1 : Insert the  $\Phi 8$  cable
  - $\Phi 7$  hole x 1 : Insert the  $\Phi 7$  cable
  - $\Phi 5.5$  hole x 4 : Insert the  $\Phi 5.5$  cable
  - $\Phi 5$  hole x 2 : Insert the  $\Phi 5$  cable
  - $\Phi 3$  hole x 3 : Insert the  $\Phi 3$  cable

 Do not remove silicon bars where there is no cable connection.

This will lessen the protection of the display against water and may result in a malfunction due to water damage, which will not be covered by the warranty.

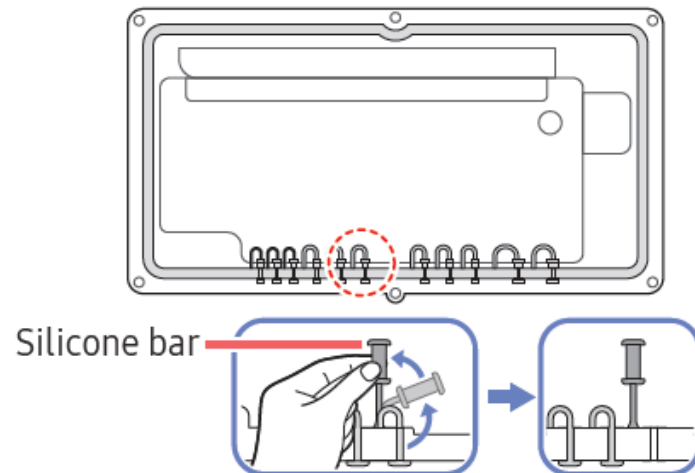

- After the completion of cabling, ensure that there is no gap between the set panel and the silicon covers.

 A gap may result in water damage and product malfunction.

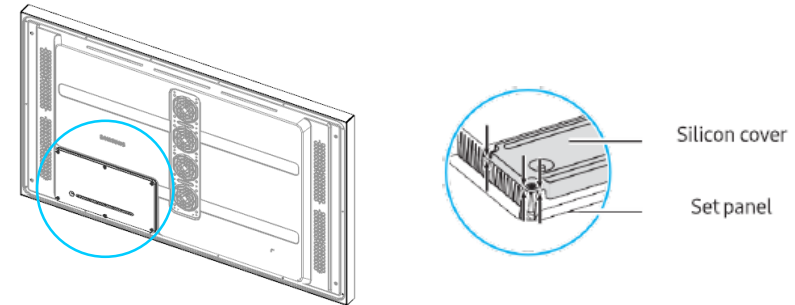

- After all the cables are connected, make sure to close the cover and fasten the screws to ensure that it is water tight. (Torque : 10~12kgf-cm)

 Only remove the cover under the following environmental condition.

Environment : Temperature (below 25°C), humidity (below 50%)

Duration : Less than 2hours (maximum allowed duration without cover)

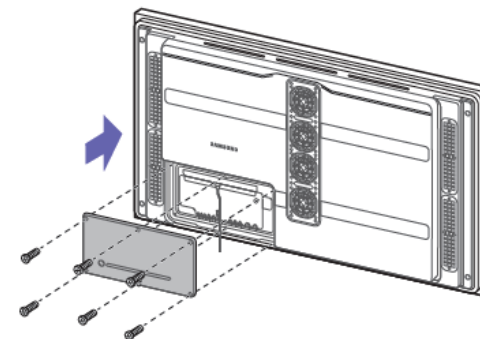

## Cleaning the protection glass

- **A** (Areas except the Magic-Glass) : Use a clean, soft cloth dampened with water to wipe off the surface.
  - **B** (Magic-Glass) : Wipe off the surface periodically with a clean, soft cloth dampened with water or glass cleaner. (cleaning cycle : within 1 month)
-  For dirt that cannot be removed, use an ethanol based cleaner.
- After a rain, use a clean, soft cloth to wipe off rain drops or dirt from the glass.

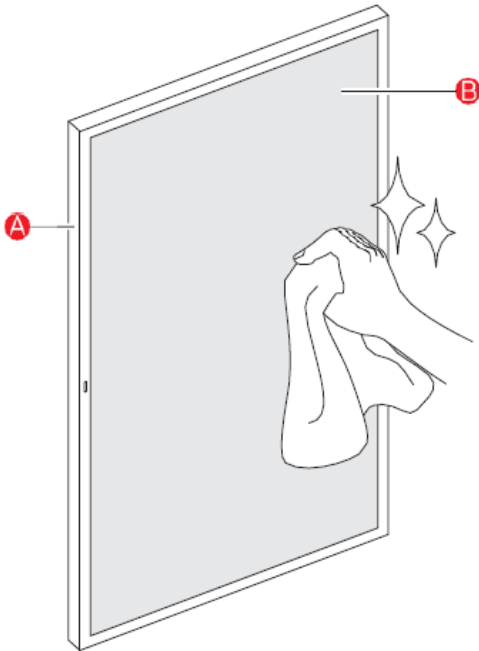

# Cleaning

---

## Cleaning the inlet and outlet

- Use a brush to remove any debris from the inlet and outlet openings.
- To remove tough stains, wipe using a cloth with a small amount of ethanol based cleaner.
- If washing display with water, keep the pressure below 0.5 bar.
- When installing an enclosure, the unit's inlet and outlet should not be blocked by dust or other materials.
- Inlet and Outlet of Enclosure also should be maintained and cleaned.

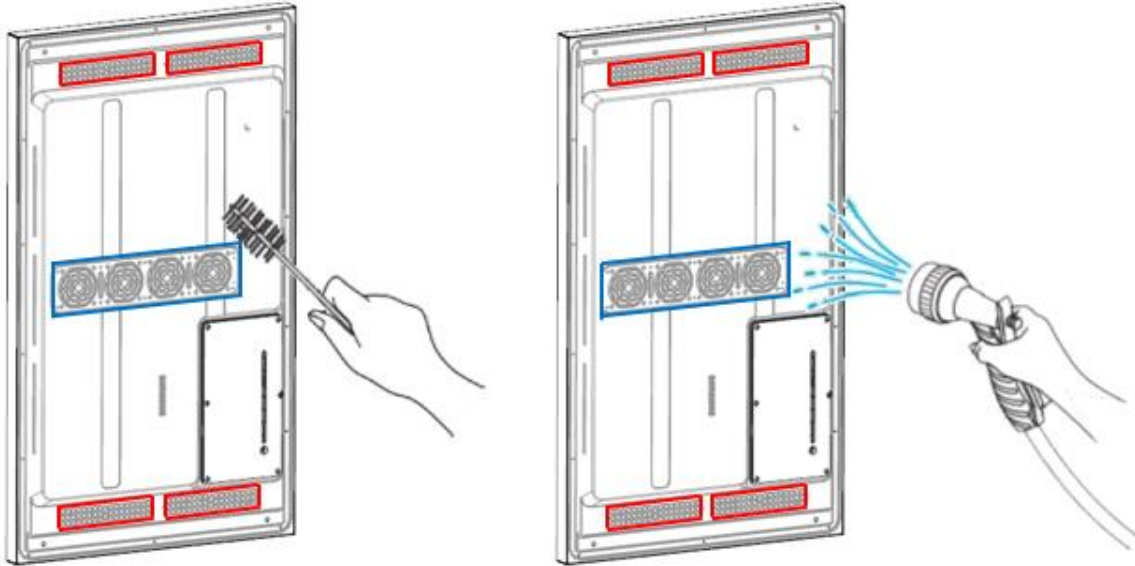

**End of Doc.**